

AC Series Max Flow Air Treatment

Filtre Regulator + Lubricator

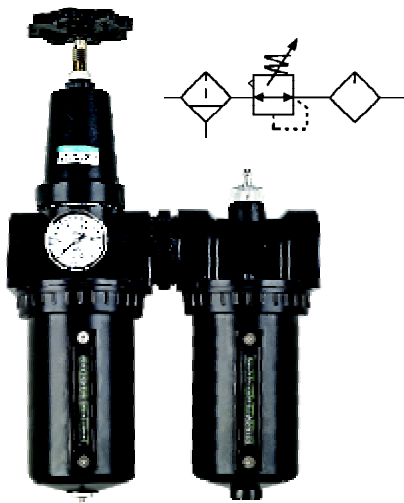

Type	AC901-15	AC901-20
Port size G	1 1/2"	2"
Gauge thread G	1/4"	
Fluid	Compressed Air	
Operating pressure range MPa	0.15~0.85	
Ambient temperature °C	-10~60	
Filter precision	Standard : 20 μ m	
Cup material	Die-casting Aluminum	

How to order

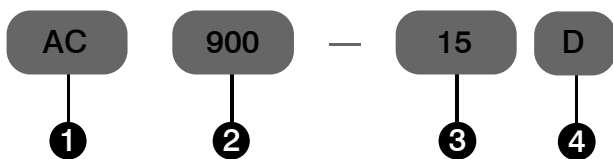

①	AC Filter Regulator+Lubricator
②	Type : 901
③	Port size : 15:G1 1/2", 20:G2"
③	Differential pressure drain, D:Auto-drain;

Inner Structure drawing

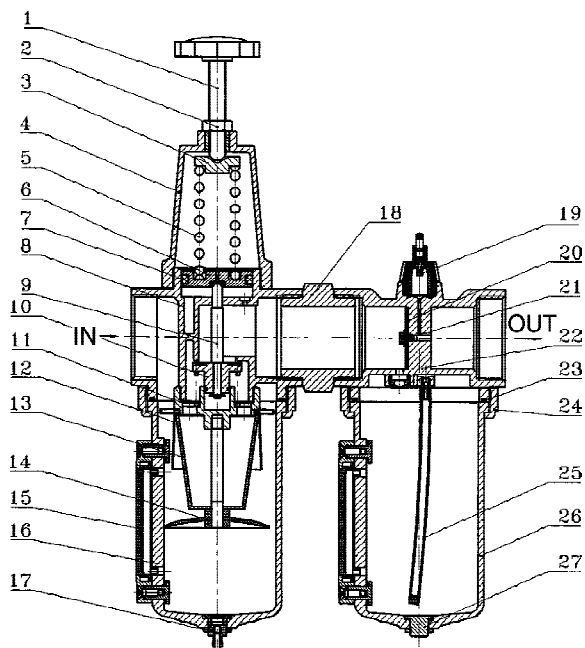

No	Code	No	Code
1	Handle wheel	15	Visual oil window
2		16	Water cup
3		17	Drainer
4		18	Connector
5		19	Oil window components
6		20	Damping fin
7		21	Damping nut
8		22	Lubricator body
9		23	O-ring
10		24	Nut
11		25	Oil tube
12		26	Oil cup
13		27	Plug
14			