

AFC,BFC Air Source Treatment Unit

Filter Regulator+Lubricator

Specification:

Type	AFC2000A	BFC2000A	BFC3000A	BFC4000A
Port size G	1/4"	1/4"	3/8"	1/2"
Gauge thread G	1/8"			
Fluid	Compressed Air			
Filter precision	5µm or 40 µm			
Operating pressure range MPa	0.15~0.85			
Max.Flow rate L/min	700			1400
Ambient temperature °C	-10~60			
Oil recommended	ISO VG32			
Optional	-	●	●	●

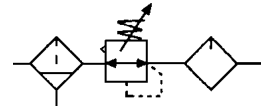

How to order:

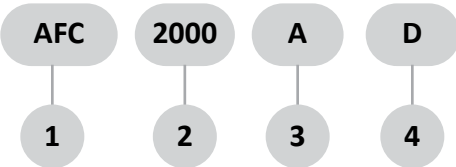

1	AFC,BFC Filter Regulator+Lubricator
2	2000:G1/4" , 3000:G3/8" ,4000:G1/2"
3	A: Improved type ; Blank: Old type
4	□: Differential pressure drain , D: Auto-drain;

Inner structure drawing:

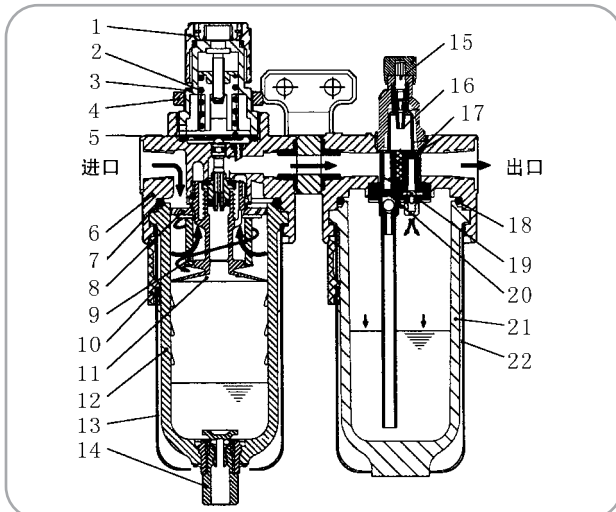

No	code	No	code
1	Pressure nut	12	PC cup
2	Regulator spring	13	Guard cup
3	Regulator basic	14	Drain
4	Fixed ring	15	Oil adjuster
5	Diaphragm	16	Doom subassembly
6	Filter regulator body	17	Toggle piece
7	O-ring	18	O-ring
8	Block ring	19	Stop-back valve
9	Cartridge	20	Rotated ring
10	Press-button	21	PC cup
11	Cartridge basic	22	Guard cup

AFC,BFC Air Treatment Unit

Dimension (mm):

■ AFC Series

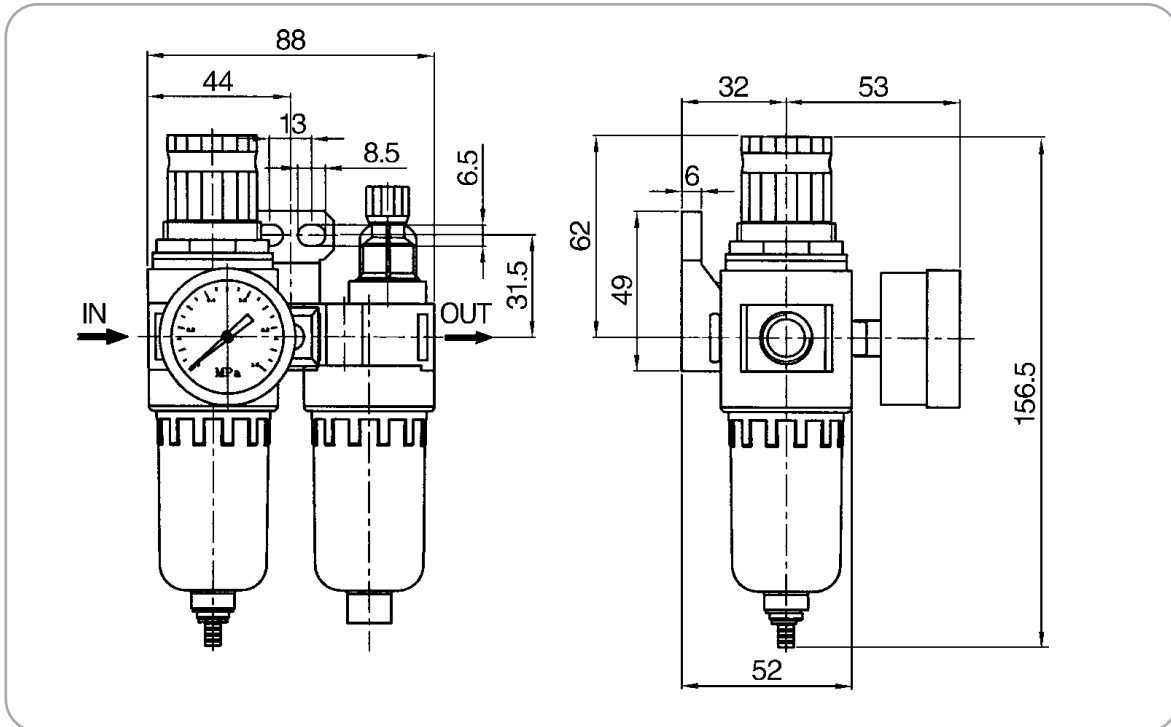

■ BFC Series

