

## SDA Series Thin Cylinder

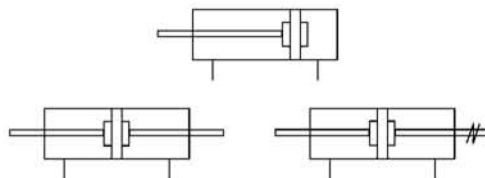

### Character

- Has ultra thin desings,light weight,occupies smaller space than traditional cylinder.
- Easy maintenance and disassembly.
- Inner and outer thread desing in piston ends which can adapts to all circustances.
- Non-lubrication desing,may attached with sensor.



### Specification

Mode	12	16	20	25	32	40	50	63	80	100
Motion	Double acting									
Series	SDA, SDAD, SDAJ									
Fluid	air									
Operating pressure range (Mpa)	0.1~0.9									
Operating speed (mm/sec)	50-500									
Ambient temperature (°C)	-10~70°C									
Port size	M5			1/8"			1/4"		3/8"	

### How to order

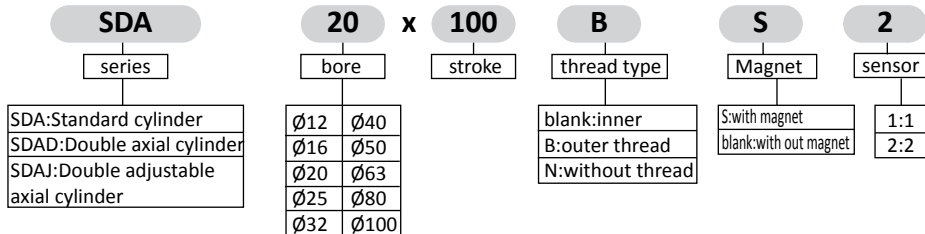

### Inner structure drawing

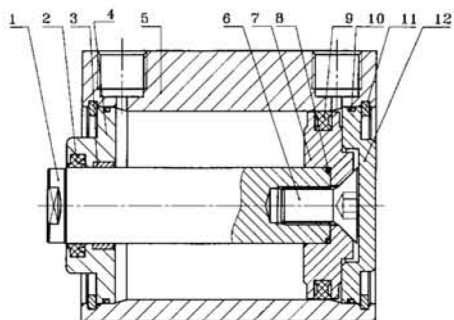

1	piston rod	7	piston
2	compagesseal	8	O-ring
3	oiled bearing	9	C-ring
4	front cover	10	O-ring
5	tube	11	springiness washer
6	inner hexaagon bolt	12	rear cover

SDA Series Thin Cylinder

Dimension

■  $\phi$  12~16

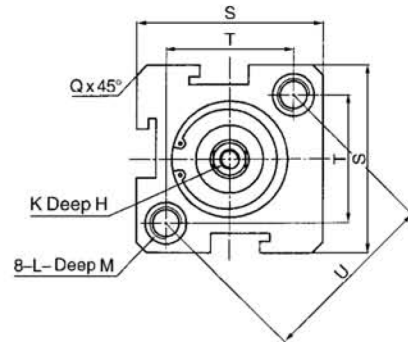
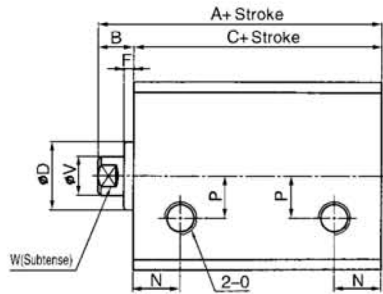

■  $\phi$  20~100

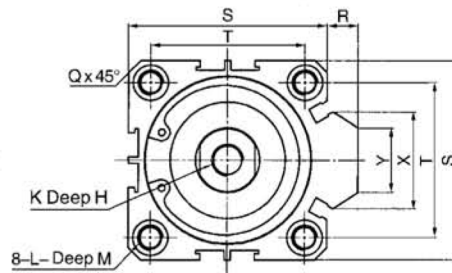
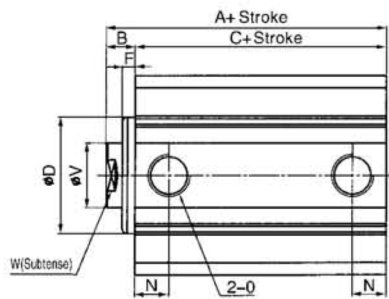

Type symbol/bore	standard			with magnet			D	F	H		K
	A	B	C	A	B	C			Stroke≤10	Stroke>10	
12	22	5	17	32	5	27	10.2	1	6		M3
16	24	5.5	18.5	34	5.5	28.5	10.5	1.5	6		M3
20	25	5.5	19.5	35	5.5	29.5	15	1.5	8		M4
25	27	6	21	37	6	31	17	2	10		M5
32	31.5	7	24.5	41.5	7	34.5	22	3.5	12		M6
40	33	7	26	43	7	36	28	3	12		M8
50	37	9	28	47	9	38	36	5	15		M10
63	41	9	32	51	9	42	38	3.5	15		M10
80	52	11	41	62	11	51	45	4	15	20	M14 x 1.5
100	63	12	51	73	12	61	50	5	18	20	M18 x 1.5

symbol/bore	L	M	N	O	P	Q	R	S	T	U	V	W	X	Y
12	M3	12	6.3	M5	6	1.6	-	25	16.2	23	6	5	-	-
16	M3	12	7.3	M5	6.5	1.6	-	29	19.8	28	6	5	-	-
20	M4	14	7.4	M5	-	2.1	2.2	34	2	-	8	6	11.3	10
25	M5	20.5	8.5	M6	-	3.1	2	40	4	-	10	8	12	10
32	M6	20.5	9	M6	-	2.1	6	43.7	34	-	12	10	18.3	15
40	M8	22.5	9.5	M8	-	2.2	6.7	52.1	40	-	16	14	21.3	16
50	M10	28.5	10.5	M8	-	4.2	9.7	61.8	48	-	20	17	30	20
63	M10	24	12	M8	-	3.2	9.7	74.6	60	-	20	17	28.7	20
80	M12	25	13	M12	-	3.6	10	94.4	74	-	25	22	36	26
100	M14	33	17	M14	-	3.6	10.1	114.4	90	-	32	27	35	26

SDA Series Thin Cylinder

Outer thread dimension

■  $\phi$  12~16

■  $\phi$  20~100

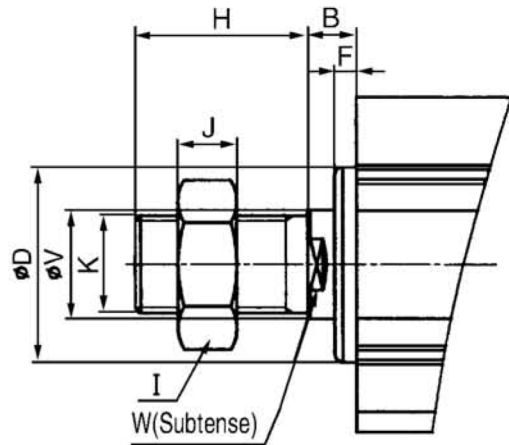
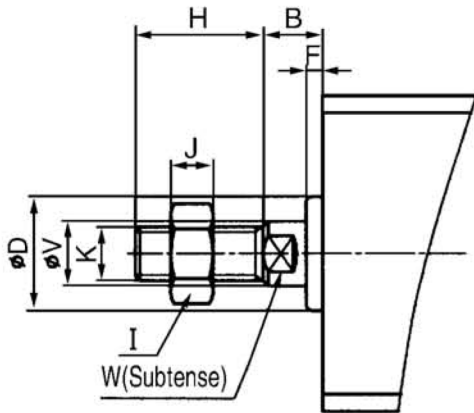

symbol/bore	B	D	F	H	I	J	K2	V	W
12	5	10.2	1	12	8	4	M5	6	5
16	5.5	10.2	1.5	12	8	4	M5	6	5
20	5/5	15	1.5	15	10	5	M6	8	6
25	6	17	2	17	12	6	M8	10	8
32	7	22	3.5	18	17	6	M10x1.25	12	10
40	7	28	3	28	19	8	M14x1.5	16	14
50	9	36	5	28	27	11	M18x1.5	20	17
63	9	38	3.5	28	27	11	M18x1.5	20	17
80	11	45	4	33	32	13	M22x1.5	25	22
100	12	50	5	38	36	13	M26x1.5	32	27

SDAD Series

Dimension

■  $\phi$  12~16

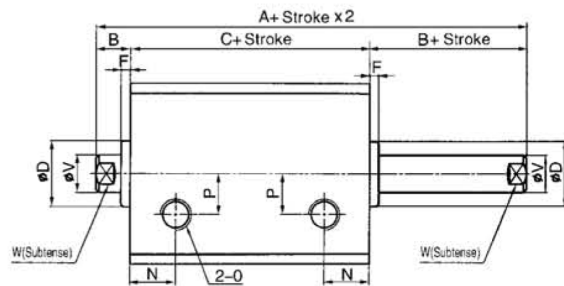
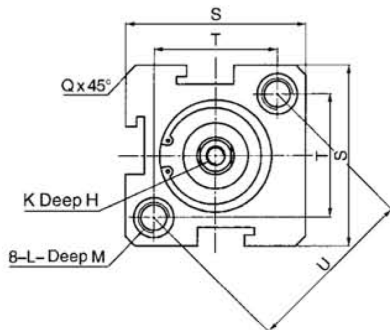

SDAD Series

Dimension

■  $\phi$  20~100

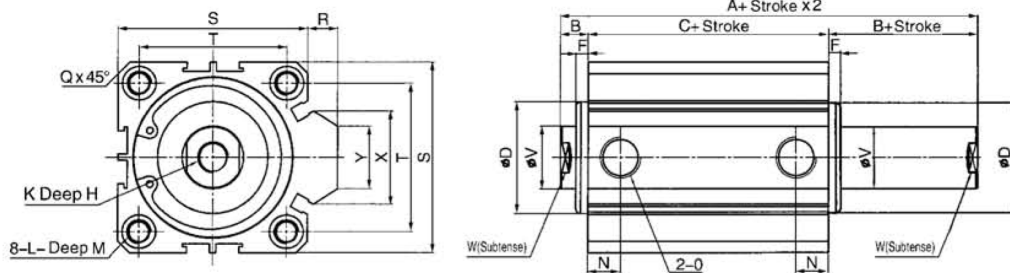

Type symbol/bore	standard			with magnet			D	F	H		K
	A	B	C	A	B	C			Stroke≤10	Stroke>10	
12	27	5	17	37.5	5	27	10.2	1	6		M3x0.5
16	29.5	5.5	18.5	39.5	5.5	28.5	10.5	1.5	6		M3x0.5
20	30.5	5.5	19.5	40.5	5.5	29.5	15	1.5	8(stroke=5,be 6.5)		M4x0.7
25	33	6	21	43	6	31	17	2	10(stroke=5,be 7)		M5x0.8
32	38.5	7	24.5	48.5	7	34.5	22	3.5	8	12	M6x1
40	40	7	26	50	7	36	28	3	9	12	M8x1.25
50	46	9	28	56	9	38	36	5	11	15	M10x1.25
63	50	9	32	60	9	42	38	3.5	11	15	M10x1.25
80	63	11	41	73	11	51	45	4	14	20	M14 x 1.5
100	75	12	51	85	12	61	50	5	18	20	M18 x 1.5

symbol/bore	L	M	N	O	P	Q	R	S	T	U	V	W	X	Y
12	M3x0.5	12	6.3	M5	6	1.6	-	25	16.2	23	6	5	-	-
16	M3x0.5	12	7.3	M5	6.5	1.6	-	29	19.8	28	6	5	-	-
20	M4x0.7	14	7.4	M5	-	2.1	2.2	34	2	-	8	6	11.3	10
25	M5x1	20.5	8.5	M5	-	3.1	2	40	4	-	10	8	12	10
32	M6x1	20.5	9	G1/8"	-	2.1	6	43.7	34	-	12	10	18.3	15
40	M8x1.25	22.5	9.5	G1/8"	-	2.2	6.7	52.1	40	-	16	14	21.3	16
50	M8x1.25	28.5	10.5	G1/4"	-	4.2	9.7	61.8	48	-	20	17	30	20
63	M8x1.25	24	12	G1/4"	-	3.2	9.7	74.6	60	-	20	17	28.7	20
80	M12x1.75	25	13	G3/8"	-	3.6	10	94.4	74	-	25	22	36	26
100	M14x2	33	17	G3/8"	-	3.6	10.1	114.4	90	-	32	27	35	26

SDAD Series

Dimension

■  $\phi$  12~16

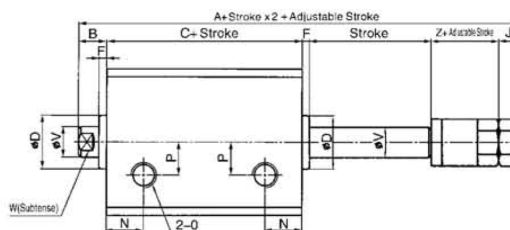
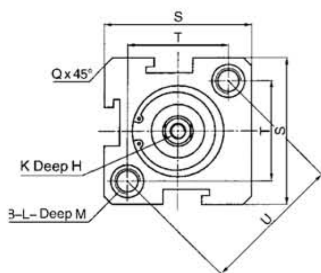

■  $\phi$  20~100

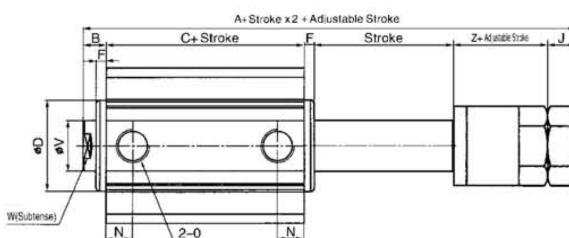
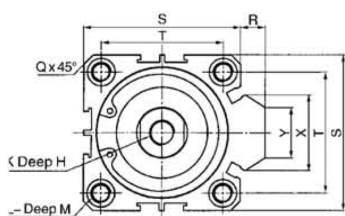

Type symbol/bore	standard			with magnet			D	F	H		K
	A	B	C	A	B	C			Stroke≤10	Stroke>10	
12	40	5	17	50	5	27	10.2	1	6		M3x0.5
16	42.5	5.5	18.5	52.5	5.5	28.5	10.5	1.5	6		M3x0.5
20	47.5	5.5	19.5	57.5	5.5	29.5	15	1.5	8(stroke=5,be 6.5)		M4x0.7
25	54	6	21	64	6	31	17	2	10(stroke=5,be 7)		M5x0.8
32	62	7	24.5	72	7	34.5	22	3.5	8	12	M6x1
40	65	7	26	75	7	36	28	3	9	12	M8x1.25
50	74	9	28	84	9	38	36	5	11	15	M10x1.25
63	76.5	9	32	86.5	9	42	38	3.5	11	15	M10x1.25
80	93	11	41	103	11	51	45	4	14	20	M14 x 1.5
100	105	12	51	115	12	61	50	5	18	20	M18 x 1.5

symbol/bore	L	M	N	O	P	Q	R	S	T	U	V	W	X	Y	Z
12	M3x0.5	12	6.3	M5	6	1.6	-	25	16.2	23	6	5	-	-	13
16	M3x0.5	12	7.3	M5	6.5	1.6	-	29	19.8	28	6	5	-	-	13
20	M4x0.7	14	7.4	M5	-	2.1	2.2	34	2	-	8	6	11.3	10	16
25	M5x1	20.5	8.5	M5	-	3.1	2	40	4	-	10	8	12	10	19
32	M6x1	20.5	9	G1/8"	-	2.1	6	43.7	34	-	12	10	18.3	15	21
40	M8x1.25	22.5	9.5	G1/8"	-	2.2	6.7	52.1	40	-	16	14	21.3	16	21
50	M8x1.25	28.5	10.5	G1/4"	-	4.2	9.7	61.8	48	-	20	17	30	20	21
63	M8x1.25	24	12	G1/4"	-	3.2	9.7	74.6	60	-	20	17	28.7	20	21
80	M12x1.75	25	13	G3/8"	-	3.6	10	94.4	74	-	25	22	36	26	24
100	M14x2	33	17	G3/8"	-	3.6	10.1	114.4	90	-	32	27	35	26	24