

Basınç Sıralama Valfleri / Sequence Valve



Technical specification

Specification	03	06	10	
Max. working pressure (MPa)	31.5			
Max. Flow (L/min)	250	500	600	
Working fluid	Mineral oil; phosphate-ester			
Fluid temp. (°C)	-20~70			
Viscosity (mm²/s)	12~380			
Working press (MPa)	5	10	20	31.5
Weight (kg)	YS Model	2.6	3.5	4.4
Cleanliness	The maximum allowable cleanliness of the oil should be according to 9th degree of Standard NAS1638. It is suggested that the minimum filter rating should be $\beta_{10} \geq 75$.			

YS pilot-operated sequence valve is used to control action sequence of actuators in hydraulic systems so as to achieve automatic control. By changing the control mode, it can serve as back pressure valve, unload valve, bypass valve and sequence valve. In addition, an internal supply internal discharge or an external supply internal discharge sequence valve can also be used as a balance valve if it includes a check valve.

Model description

YS * - * - * * - * * / * * 50 *

<p>Sequence valve</p> <p>Omit Pilot operated valve C Pilot operated without main cartridge (not marked diameter) Pilot operated with main cartridge (marked diameter)</p> <p>Specification 03 10NS 06 20NS 10 30NS</p> <p>Working press 5 to 5MPa 10 to 10MPa 20 to 20MPa 31.5 to 31.5MPa 35 to 35MPa</p> <p>Omit Without check valve D With check valve</p>	<p>Remarks</p> <p>Serial number</p> <p>Seal material Omit NBR Seals V FPM Seals</p> <p>Pilot operated drainage port thread Omit G1/4" 2 M14X1.5</p> <p>Omit Intl cntrl intl disch X Extl cntrl intl disch Y Intl cntrl extl disch XY Extl cntrl extl disch</p> <p>1 Rotary knob 2 Sleeve with hexagon and protective cap</p>
----------------------------------------------------------------------------------------------------------------------------------------------------------------------------------------------------------------------------------------------------------------------------------------------------------------------------------------------------------------------------------------------------------	--------------------------------------------------------------------------------------------------------------------------------------------------------------------------------------------------------------------------------------------------------------------------------------------------------------------------------------------------------------

Basınc Sıralama Valfleri / Sequence Valve

Code symbol

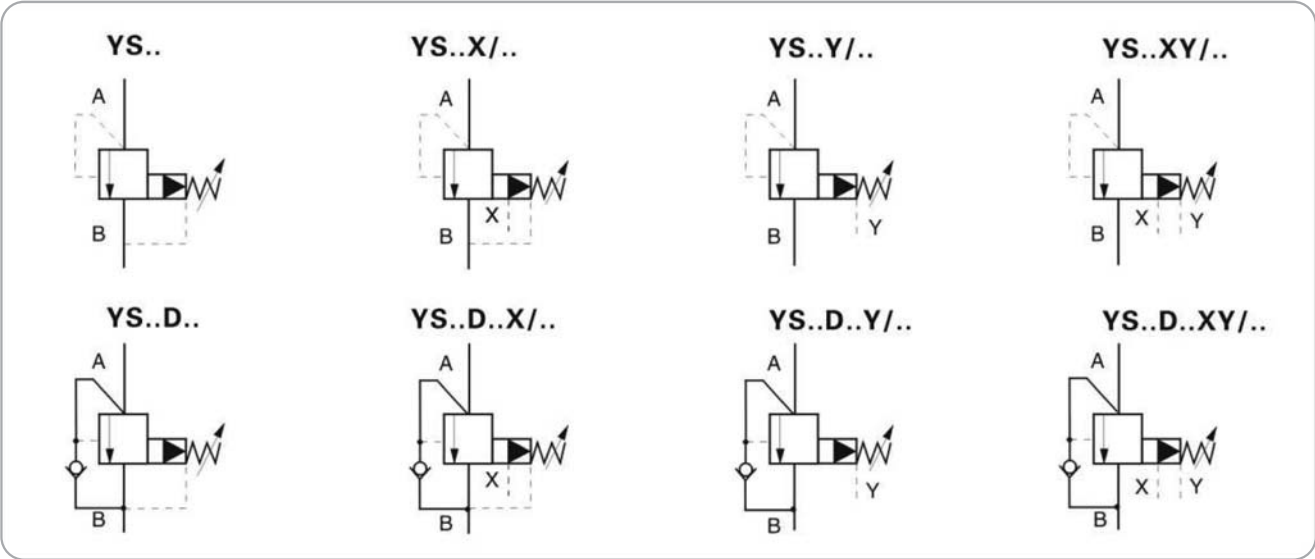

Performance curve (Measured at: Test under $v=41\text{mm}^2/\text{s}$ and $t=50^\circ\text{C}$)

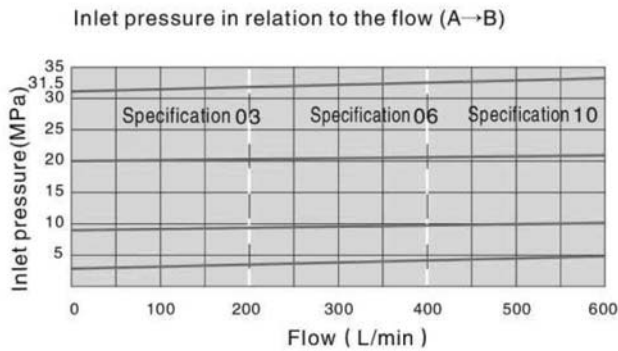

Minimum settable pressure in relation to the flow (A→B) (=bypass pressure version "...X...")

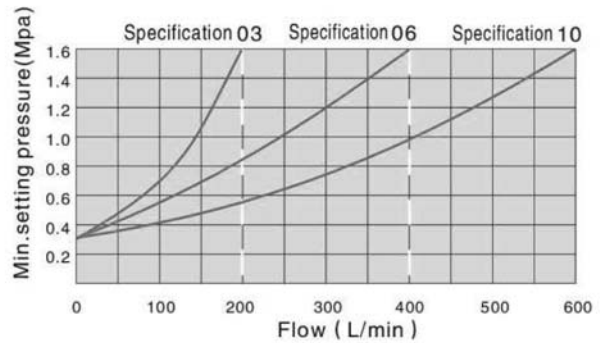

The characteristic curves are valid for the complete flow range

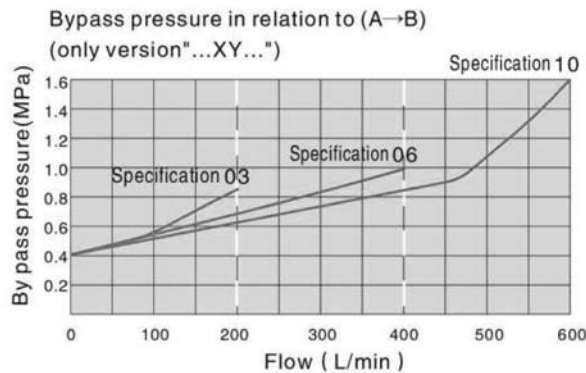

The curve $\Delta P-Q$ pass through the check valve

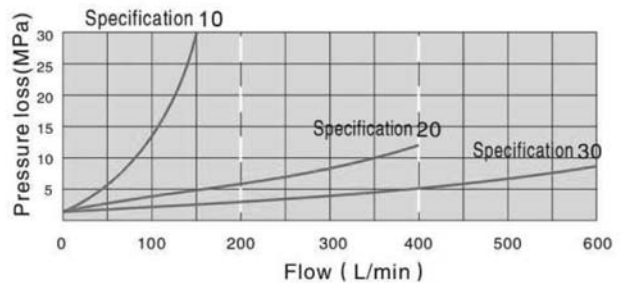

The characteristic curves are valid for outlet pressure $P_B=0$ for the complete flow range

Basınç Sıralama Valfleri / Sequence Valve

External dimensions

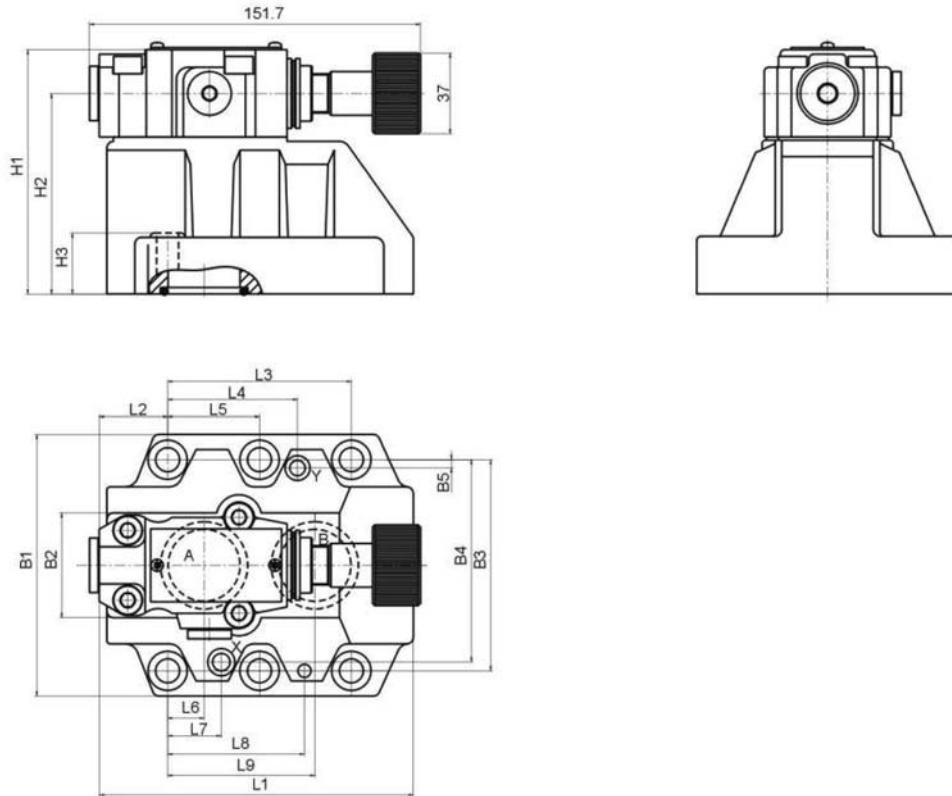

Subplate mounting size

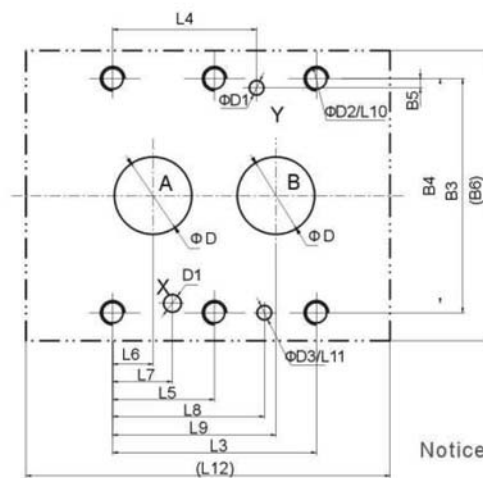

Specification	Mounting screw	Tighten torque
YS-03	4-M10x50-10.9	75Nm
YS-06	4-M10x60-10.9	75Nm
YS-10	6-M10x70-10.9	75Nm

Notice: The surface, connecting with the valve, should be Ra0.8 roughness, and 0.01/100mm flatness.

Model	L1	L2	L3	L4	L5	L6	L7	L8	L9	L10	L11	L12	B1	B2	B3	B4	B5	B6	H1	H2	H3	D	D1	D2	D3
YS-03	96	35.5	42.9	21.5	-	7.2	21.5	31.5	35.8	23	6	98	85	80	66.7	58.8	7.9	87	112	92	28	12	6	M10	7
YS-06	116	37.5	60.3	39.7	-	11.1	20.6	44.5	49.2	24	6	118	102	59.5	79.4	73	6.4	104	122	102	38	25	6	M10	7
YS-10	145	33	84.2	59.5	42.1	16.7	24.6	62.7	67.5	25	6	147	120	76	96.8	92.8	3.8	149	130	110	46	32	6	M10	7